

ALUMINUM SECTIONAL RAMP

Handi-Ramp®

ALUMINUM SECTIONAL RAMP SERIES™

The Aluminum Sectional Ramp System from Handi-Ramp is designed for ease of assembly and flexibility.

Its modular design, with 4 foot, 5 foot and 6 foot sections, enable one ramp system to solve many access barriers. All sections are completely interchangeable and because the material is lightweight and heavy-duty, this system is the perfect option for meeting ADA requirements when a permanent ramp cannot be installed.

Easy to Install and Store!

Because of its modular design, a single system can be used to achieve access to many different barriers. Simply choose the length of ramp required and connect the sections together.

Ramp sections are lightweight and can fit in a small storage space when not in use. For example, a 24 foot ramp (four - six foot long sections, without handrails) will store in a space, 76" tall x 42" deep x 16" wide.

Customizable Solutions

At Handi-Ramp we know that each ramp application is unique and may require some customization. Our expert design team is ready to work with you and/or your dealer to meet your specific needs.

Our patented non-skid surface exceeds all governmental specifications. Handrails are also available and are recommended for all rises over 6" in height.

Each ramp system contains a *Ramp Base*, one or more *Ramp Sections*, and an *Upper Ramp Lip*. Standard width for our sections is 36".



The flexibility and portability of this system allows for many uses. Here an eight foot ramp is in use as a boarding ramp for the Anita Dee II.

Patented non-skid surface provides excellent footing and traction in most conditions. (This surface exceeds all federal specifications for non-skid surfaces.)



Handi-Ramp®

The First Name in Accessibility Since 1958

510 North Avenue, Libertyville, IL 60048 • Phone: (800) 876-RAMP • FAX: (847) 816-8866 • www.handiramp.com

ALUMINUM SECTIONAL RAMP

Handi-Ramp®

Examples of Typical Ramp Configurations

Straight Ramp 16 Feet Long

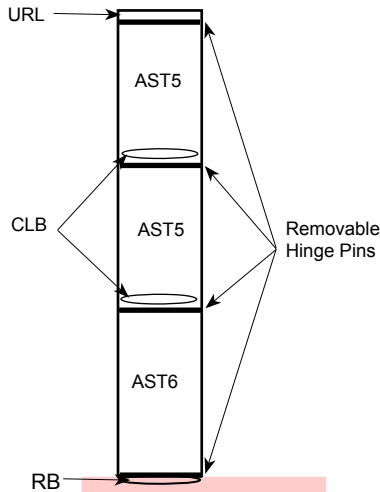

Item	ID #	Quantity Needed
5' Ramp Section	AST5	2
6' Ramp Section	AST6	1
Upper Ramp Lip	URL	1
Connecting Brace	CLB	2
Ramp Base	RB	1

90° Turning Platform With 12 Foot Ramp

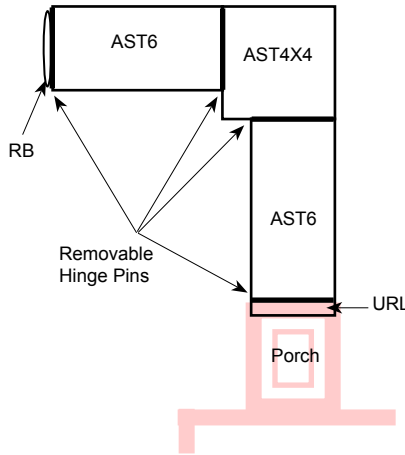

Item	ID #	Quantity Needed
6' Ramp Section	AST6	2
4' X 4' Platform	AST4X4	1
Upper Ramp Lip	URL	1
Ramp Base	RB	1

180° Turning Platform With 20 Foot Ramp

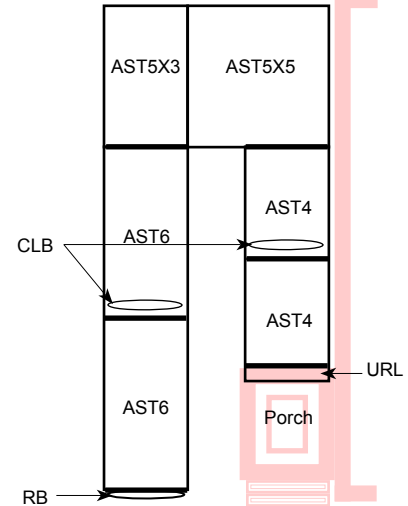

Item	ID #	Quantity Needed
4' Ramp Section	AST4	2
6' Ramp Section	AST6	2
5' X 5' Platform	AST5X5	1
5' X 3' Platform Add-on	AST5X3	1
Upper Ramp Lip	URL	1
Connecting Brace	CLB	2
Ramp Base	RB	1

HANDRAILS

Handi-Ramp® steel or high strength aluminum, handrail and railing systems meet all ADA accessibility standards, are maintenance free and ideal for stairways, ramps, walkways, platforms, bridges and machine barriers.

Handrails are sold separately and in conjunction with our ramp systems. They are simple to install and remove by simply sliding into receiver tubes which are welded onto each ramp section.

Product Description	Product Number	Capacity	Approximate Weight
4 Foot Ramp	AST4	750 lbs.	39 lbs
5 Foot Ramp	AST5	750 lbs.	49 lbs
6 Foot Ramp	AST6	750 lbs.	59 lbs
4' X 4' Platform	AST4X4	750 lbs.	54 lbs
5' X 5' Platform	AST5X5	750 lbs.	74 lbs
5' X 3' Platform Add-on	AST5X3	750 lbs.	39 lbs
Hand Rail Section (Each Side)	HR		17 lbs
Ramp Base	RB		4.5lbs
Upper Ramp Lip	URL		5.5lbs
Connecting Leg Brace	CLB		7.5 lbs



Common Handrail Applications

Stairways
Ramps
Pools
Decks
Escalators
Porches
and more!

Handi-Ramp®

The First Name in Accessibility Since 1958